

ACQUISITIONS™
OF LONDON
est. 1974

Acquisitions House, 24-26 Holmes Road, London, NW5 3AB
T: +44 (0)20 7482 2949 F: +44 (0)20 7267 4361
E: sales@acquisitions.co.uk W: www.acquisitions.co.uk



ACQUISITIONS™
OF LONDON
est. 1974





Fine carving by master craftsmen



Detail of cast finial



The Winchester surround in limestone

Exquisitely recaptured period detailing



Inspired by History CRAFTED BY US

Even in these days of ubiquitous central heating, a house does not seem like a home without a hearth. Whether used for warmth or simply for its aesthetic value, a beautiful fireplace is always a focal point, an imposing presence that lends architectural elegance to its surroundings.

Founded in 1974, Acquisitions began life as an architectural antique business but soon specialised in rescuing beautiful antique fireplaces that had been evicted from their home in the name of fashion. As suitable originals became scarcer, we set about

the ambitious task of replicating Victorian cast-iron fireplaces, and were proud to lead the way in restoring the period mantelpiece to its rightful place in the British public's consciousness.

Today, the Acquisitions collection of 'continuations' – the word 'reproductions' does not do our products justice, since they are so meticulously recreated using authentic skills, techniques and materials – is one of the finest and most comprehensive in the world, encompassing every material from marble to cast-iron, and every style from Georgian to modern-day.

CONTENTS

02	LIMESTONE SURROUNDS
24	GRANITE SURROUNDS
26	MARBLE SURROUNDS
42	BESPOKE SURROUNDS
46	CAST-IRON SURROUNDS
51	FIREPLACE INTERIORS
54	INSERTS & HOB GRATES
56	INSERTS & PANELS
58	BASKETS & DOG GRATES
60	FOUR TYPES OF FUEL
61	NEED TO KNOW

ACQUISITIONS[™]
OF LONDON
est. 1974

LIMESTONE SURROUNDS

SOFT ENOUGH TO BE WORKED WITH RELATIVE EASE, WITH A STRENGTH THAT SURVIVES THE CENTURIES, STONE HAS BEEN ONE OF THE MAIN BUILDING BLOCKS OF CIVILISATION. ITS HONEST TEXTURE, SOFT TONE AND SATISFYING SOLIDITY MAKE IT THE VERSATILE CHOICE FOR ALL STYLES OF FIRE SURROUND AND EVERY TYPE OF INTERIOR, FROM CLASSIC TO CONTEMPORARY



Award Winning Fireplaces

Hand-carved anthemion leaves, typical classical motifs, form the capitals of the **SPRINGFIELD** chimneypiece seen above and overleaf. This surround, previously only available in marble but here recognised with not one but two **Hearth & Home Fireplace Awards**. Teamed with our

polished-steel Somerset hob grate, a strikingly simple design based on a late-18th-century original, the **SPRINGFIELD** has an understated beauty which works equally well in any setting.



Springfield 63	inches	mm
Shelf width	63 ¹ / ₂	1613
Shelf depth	10	254
Base width	56 ¹ / ₂	1435
Rebate	1 ¹ / ₂	38
Overall height	49 ³ / ₄	1263
Opening height	38 ¹ / ₂	978
Opening width	38 ¹ / ₂	978

Springfield 54	inches	mm
Shelf width	54	1370
Shelf depth	8 ¹ / ₄	208
Base width	51 ¹ / ₂	1307
Rebate	1 ¹ / ₂	38
Overall height	45 ³ / ₄	1151
Opening height	36 ¹ / ₂	927
Opening width	36 ¹ / ₂	927

Ask for 54" shelf profile.

IT'S PART OF OUR PHILOSOPHY THAT YOU CAN COMFORTABLY
 COMBINE TRADITIONAL WITH CONTEMPORARY IN ONE SETTING.
 IT'S ALL A QUESTION OF BALANCE



The **FLAT VICTORIAN CLASSIC** limestone surround is simplicity at its elegant best, a design that is equally at home in modern and traditional interiors. It is pictured with our new Prince highlight-polished insert, an appropriately unadorned style based on a late-Regency design, and a boxed and lipped limestone hearth.

Flat Victorian Classic	inches	mm
Shelf width	58	1473
Shelf depth	8	203
Base width adjustable	54-50	1372-1270
Rebate	1	25
Overall height	45 ³ / ₄	1160
Opening height	36 ¹ / ₂	930
Opening width	36 ¹ / ₂	927
54" / 1372mm shelf also available		





BEAUTY IS NOT A FINITE RESOURCE – THERE IS ALWAYS MORE TO BE FOUND. WE NEVER STOP EXPLORING WAYS OF BRINGING ELEGANCE AND LUXURY TO MODERN LIVING

A fresh take on a traditional chimneypiece: our **WILLIAM IV CORBEL** is now available in limestone, which gives its Regency-style recessed panels and reeded shelf moulding a new, more contemporary feel. The simplicity and lightness of the surround and matching limestone hearth set off the intricate arch of the Regent highlight cast-iron insert – an exclusive pattern made up of five separate castings which are assembled and finished by hand.



William IV Corbel	inches	mm
Shelf width	65	1650
Shelf depth	10	254
Base width	57 ³ / ₈	1458
Rebate	1 ¹ / ₂	38
Overall height	49 ³ / ₈	1255
Opening height	39 ³ / ₄	1010
Opening width	39 ³ / ₈	1000

GREAT IDEAS EVOLVE. CONTEMPORARY DESIGN CAN TRANSFORM HISTORICAL ELEMENTS INTO SOMETHING DIFFERENT YET RESONANT, NEW YET REASSURINGLY FAMILIAR



Additional top shelf available

The **LARGE RUBENS BOLECTION** is hand-crafted from solid limestone; the style also comes in a smaller size. It is shown here in a striking new combination, with solid Stirling steel slips, a back box, the Two Ball Modern basket (suitable for solid fuel or gas) and a limestone hearth.

Large Rubens Bolection	inches	mm
Shelf width	55½	1410
Min shelf depth	3½	89
Base width	56	1424
Rebate	1½	38
Overall height	47	1194
Height inc. top shelf	57	1448
Opening height	39	991
Opening width	39	991

Stirling slips and back box:
 W: 40in (1016mm)
 H: 40in (1016mm) D: 12in (305mm)

Min site opening:
 W: 29in (734mm)
 H: 34in (863mm) D: 12½in (312mm)
 Also made to size



SOME THINGS ARE EYE-CATCHING IN THEIR UNDERSTATEMENT. THE SIMPLER THE DESIGN, THE MORE THE SUBTLITIES OF THE STONE STAND OUT

Pared down to the simplest lines, the ultra-modern SLOANE limestone surround in fact has its origins in 1930s styling. Matched with our plain, brushed-steel 5mm slips and back box, the Two Ball Modern steel basket and a lipped limestone hearth, this is a look that achieves maximum effect with minimal fuss.

Sloane	inches	mm
Depth	5	127
Base width	54 ³ / ₄	1391
Rebate	1	25
Overall height	45 ¹ / ₂	1153
Overall width	54 ³ / ₄	1391
Opening height	37 ¹ / ₂	953
Opening width	39	991





TRUE SOPHISTICATION LOOKS EFFORTLESS. UNDERSTATEMENT AND SUBTLE TOUCHES OF ORIGINALITY ARE HALLMARKS OF DISTINCTION

Be one of the first to enjoy the cool beauty of our new LINCOLN fireplace, a versatile choice for period or modern settings. Georgian-influenced, it has a discreet contemporary twist in the shape of its unique barrel-ended frieze. The two-part construction of the shelf means that the top section can be left off, reducing the width from 58"/147cm to 54"/137cm to fit smaller chimney breasts. The handmade Imperial limestone mantel (also available in granite) is here given an up-to-the-minute look with our brushed-steel 5mm Modern steel slips and back box, Cubic Modern steel basket and matching limestone hearth.

Lincoln 58	inches	mm
Shelf width	58	1473
Shelf depth	10½	267
Base width	51½	1308
Rebate	1½	38
Overall height	48½	1232
Opening height	36½	927
Opening width	36½	927

Lincoln 54	inches	mm
Shelf width	54	1372
Shelf depth	8½	216
Base width	51½	1308
Rebate	1½	38
Overall height	46¼	1175
Opening height	36½	927
Opening width	36½	927

BIG, BOLDLY CARVED BLOCKS OF SOLID LIMESTONE PROVIDE A SENSE OF STABILITY AND IMMUTABILITY IN AN EVER-CHANGING WORLD

The generous scale, bold shapes and solid feel of our classically designed CANTERBURY limestone surround give it a pleasing contemporary twist. Ideal for spacious country houses but equally at home in town, the design teams up comfortably - as shown - with our Bloomsbury Gunmetal stove (suitable for multi-fuel or gas), along with matching limestone slips and hearth.

Canterbury	inches	mm
Shelf width	59 ³ / ₄	1520
Shelf depth	17 ³ / ₄	450
Base width	52 ³ / ₄	1340
Rebate	3	75
Overall height	47 ¹ / ₄	1200
Opening height	35 ³ / ₄	910
Opening width	35 ³ / ₄	910



DEDICATION; PASSION; OBSESSION. WHATEVER YOU CALL IT, IT'S THE REASON WE CAN TURN EVEN OUR WILDEST DREAMS INTO BREATHTAKING REALITY



Reach new heights of elegance and make a lasting impression with our stunning WINCHESTER mantel. Its classic, Gothic-style natural motifs are lovingly carved by hand from premium limestone. Here the chimneypiece is shown framing our Bloomsbury Black stove (suitable for multi-fuel or gas), with a matching limestone hearth.

Winchester	inches	mm
Shelf width	52 ¹ / ₄	1329
Shelf depth	8	203
Base width	48 ¹ / ₂	1231
Rebate	1 ¹ / ₄	34
Overall height	58 ¹ / ₂	1490
Opening height	36 ³ / ₄	937
Opening width	39 ¹ / ₂	1001



VICTORIAN CARVED CORBEL



Hand-crafted in traditional limestone, this Victorian-style mantel has prominent carved corbels; it is shown here combined with our Regent highlight cast-iron insert and polished black granite hearth.

EDWARDIAN CARVED CORBEL



Typically Edwardian in style, this limestone surround has a plain frieze and jambs with carved, shaped corbels; pictured with it are the Royal highlight cast-iron insert and polished black granite hearth.

COPENHAGEN



This minimalist limestone mantel with a hint of Art Deco, perfect for the design-conscious contemporary home, is here complemented by our Modern steel basket and a matching limestone hearth.

FLAT VICTORIAN CLASSIC



Simply elegant, and equally at home in traditional and contemporary interiors, this limestone mantel is shown with the Modern steel basket, slate slips and a matching limestone hearth.

Victorian Carved Corbel	inches	mm
Shelf width	58	1473
Shelf depth	10	254
Base width adjustable	54-50	1372-1270
Rebate	1	25
Overall height	45 ³ / ₄	1160
Opening height	36 ¹ / ₂	927
Opening width	36 ¹ / ₂	927

54" / 1372mm shelf also available

Edwardian Carved Corbel	inches	mm
Shelf width	58	1473
Shelf depth	10	254
Base width adjustable	54-50	1372-1270
Rebate	1	25
Overall height	45 ³ / ₄	1160
Opening height	36 ¹ / ₂	927
Opening width	36 ¹ / ₂	927

54" / 1372mm shelf also available

Copenhagen	inches	mm
Overall width	45	1143
Overall height	39	991
Opening height	29	737
Opening width	25	635
Depth	6	152

Flat Victorian Classic	inches	mm
Shelf width	58	1473
Shelf depth	8	203
Base width adjustable	54-50	1372-1270
Rebate	1	25
Overall height	45 ³ / ₄	1160
Opening height	36 ¹ / ₂	930
Opening width	36 ¹ / ₂	927

54" / 1372mm shelf also available

LIMESTONE SURROUNDS

DEMI-LUNE BULL'S-EYE



An authentic Georgian combination: The Demi-Lune Bull's-eye limestone mantel with our Georgian hob grate in polished cast-iron - still made to the original pattern in the same Scottish foundry - and limestone hearth.

Demi-Lune Bull's-Eye	inches	mm
Shelf width	56 ¹ / ₂	1435
Shelf depth	7	178
Base width	52 ¹ / ₂	1333
Rebate	1	25
Overall height	43 ³ / ₈	1102
Opening height	36 ¹ / ₂	927
Opening width	36 ¹ / ₂	927

54" / 1372mm shelf also available.

SMALL RUBENS BOLECTION



This scaled-down version of the Large Rubens Bolection is ideal for the smaller room and blends perfectly with a modern minimalist theme. It is pictured with our Somerset steel slips and back box, Modern steel basket and matching limestone hearth.

Small Rubens Bolection	inches	mm
Shelf width	50	1270
Shelf depth	7/10	178/250
Base width	43 ³ / ₄	1114
Rebate	1-4	25-102
Height without shelf	44	1117
Height inc. top shelf	48 ³ / ₄	1237
Opening height	39	990
Opening width	33	840

AN OBJECT OF PURE, LASTING BEAUTY IS A TOUCHSTONE IN LIFE, AND GIVES PLEASURE TO GENERATION UPON GENERATION



Solid yet satisfyingly concave, **CURVE** is an innovative addition to our collection. Unusually, each section is sculpted from a single piece of stone - a challenging and labour-intensive process. The main picture shows the mantel teamed with our Stirling steel slips and Two Ball Modern basket, while the detail shows it with the Aston steel insert.

Curve 59	inches	mm	Curve 54	inches	mm
Shelf depth	10	254	Shelf depth	8	203
Base width	59	1499	Base width	54	1372
Rebate	1	25	Rebate	1	25
Overall height	48	1219	Overall height	45 ¹ / ₄	1150
Opening height	37	940	Opening height	36 ¹ / ₂	927
Opening width	37	940	Opening width	36 ¹ / ₂	927

GRANITE SURROUND

SIMPLY TIMELESS... FROM INDIAN TEMPLES TO THE CAPSTONE OF EGYPT'S BLACK PYRAMID, GRANITE HAS BEEN USED DOWN THE MILLENNIA FOR ITS EXTRAORDINARY STRENGTH AND DURABILITY. FORMED FROM MAGMA, IT COMES IN MANY SHADES, FROM PINK TO THIS SENSUOUS INKY BLACK POLISHED TO THE HIGH GLOSS OF PIANO LACQUER. IN TODAY'S HOMES A HANDSOME, HAND-CRAFTED GRANITE MANTEL IS THE ULTIMATE LUXURY, REFLECTING THE CURRENT FASHION FOR DARKER SHADES IN DECORATION WHILE EXUDING A DRAMATIC SENSE OF POWER AND PERMANENCE

Inspired by history, crafted by us. Teamed with ornate Adam panels and our new Bloomsbury Black cast-iron and steel stove suitable for multi-fuel or gas, the LINCOLN granite chimneypiece makes a bold style statement that will live on for generations. The upper section of the shelf can be left off to fit smaller chimney breasts.

Lincoln 58	inches	mm
Shelf width	58	1473
Shelf depth	10 ¹ / ₂	267
Base width	51 ¹ / ₂	1308
Rebate	1 ¹ / ₂	38
Overall height	48 ¹ / ₂	1232
Opening height	36 ¹ / ₂	927
Opening width	36 ¹ / ₂	927

Lincoln 54	inches	mm
Shelf width	54	1372
Shelf depth	8 ¹ / ₂	216
Base width	51 ¹ / ₂	1308
Rebate	1 ¹ / ₂	38
Overall height	46 ³ / ₄	1175
Opening height	36 ¹ / ₂	927
Opening width	36 ¹ / ₂	927



MARBLE SURROUNDS

CLASSICALLY RESTRAINED, BEAUTIFULLY PROPORTIONED AND FAITHFULLY REPRODUCED FROM ORIGINAL DRAWINGS, OUR ENGLISH-STYLE MARBLE CHIMNEYPieces STRIKE A NOTE OF TIMELESS GOOD TASTE; THEIR MORE FLAMBOYANT FRENCH-INSPIRED COUNTERPARTS LEND A TOUCH OF COURTLY GRANDEUR TO ANY SETTING. WE USE THE BEST-QUALITY STONE TO GUARANTEE THE FINEST POSSIBLE DETAIL, AND FINISH EVERY ONE OF THESE OBJECTS OF DESIRE BY HAND



For the Georgian landed gentry, a marble fireplace was a symbol of affluence and continental good taste, a more refined choice than its stone predecessors. It was also the perfect place to exhibit The Orders – the rules of proportion and decoration, derived from ancient Greek and Roman buildings, which governed

architectural beauty at the time and influenced later styles. Inspired by the late-18th-century designer after whom it is named, our Empire-style THOMAS HOPE mantel (above and overleaf) is carved by hand from the finest Imperial white marble; its tapered columns recall the ancient Egyptian aesthetic. Every one of our marble fireplaces

is the result of painstaking labour from a team of highly accomplished craftsmen. Processes include cutting the blocks of marble, ‘boxing’ or adding the rebates, hand-carving the corbels, architraves and other details, and honing to a tactile sheen.

WHY SHOULD SOMETHING BE ORDINARY WHEN IT CAN BE EXCELLENT? WHY COMPROMISE WHEN WE HAVE EXACTLY WHAT YOU HAVE BEEN LOOKING FOR?



The THOMAS HOPE chimneypiece is shown here paired with another striking design, the Stirling steel insert, and a boxed and lipped granite hearth. A modern single-ribbon gas fire, operated by remote control, works well with this combination, while a log-burning option is also available. To help you co-ordinate your decorative scheme we also produce a Stirling mirror (left) which replicates the frame of the insert.

Thomas Hope	inches	mm
Shelf width	67	1702
Shelf depth	11 ³ / ₄	300
Base width	62	1575
Rebate	1	25
Overall height	48	1219
Opening height	38 ¹ / ₂	978
Opening width	38 ¹ / ₂	990
Stirling Mirror	inches	mm
Width	42	1067
Height	26	660

Also made to size



Classical pilasters with anthemion-leaf capitals distinguish the Regency-style **SPRINGFIELD** chimneypiece, a restrained design that adapts to any environment. The surround is intricately hand-carved in Imperial white marble – white being the traditional colour of choice due to its versatility and relative consistency of tone. The Somerset steel hob grate is shown with a coal-effect gas fire, though a solid-fuel option can be provided; a matching Somerset mirror and contrasting granite hearth make stylish finishing touches.

Springfield 63 inches mm

Shelf width	63½	1610
Shelf depth	10	254
Base width	56½	1436
Rebate	1½	38
Overall height	49¾	1263
Opening height	38½	978
Opening width	38½	978

Springfield 54 inches mm

Shelf width	54	1370
Shelf depth	8¼	208
Base width	51½	1307
Rebate	1½	38
Overall height	45¼	1151
Opening height	36½	927
Opening width	36½	927

Ask for 54" shelf profile

Somerset Mirror inches mm

Width	48	1219
Height	32	813

Also made to size



SOME THINGS STAND OUT WITHOUT BEING GLARINGLY OBVIOUS. THEY ARE PLEASING WITHOUT BEING FASHION-CONSCIOUS, HARMONIOUS WITHOUT BEING BORING. THEY ARE, QUITE SIMPLY, BEAUTIFUL



Against a richly coloured backdrop and polished granite hearth, our fine white marble has a cool, luminous quality. With its seductive curves and hand-carved rococo shell-and-flower centrepiece, the Louis XV-style **VERSAILLES** mantel is a real test of the mason's skill. Complementing its graceful lines is the Mildmay polished cast-iron dog basket with coal-effect fire; a solid-fuel option is also available.

Versailles	inches	mm
Shelf width front	60½	1537
Shelf width back	56	1422
Shelf depth	13½	343
Base width	59	1499
Rebate	9¾	248
Overall height	42	1067
Min opening height	31	787
Max opening height	33¾	857
Opening width	40½	1029





SENSUOUS YET SOPHISTICATED, EYE-CATCHING YET CLASSIC: SOME OF OUR MARBLE MASTERPIECES ARE NOSTALGIC TRIBUTES TO FRENCH COURTLY LIFE

CHATELAINE is an exuberant design, hand-carved in Imperial white marble in the Louis XVI style. Pictured with its namesake dog basket in cast iron and brass, Adam cast-iron panels and granite slips and hearth, it exemplifies the French-style balance of line and ornament.



Chatelaine	inches	mm
Shelf width	61	1549
Shelf depth	10½	267
Base width	58	1473
Rebate	6½	165
Overall height	47½	1207
Opening height	37	940
Opening width	42½	1080

WILLIAM IV CORBEL



NASH



GROSVENOR



OSBORNE



This elegant mantel in Imperial white marble features sculpted, tapered, hand-carved corbels and recessed panels on the jambs. It is shown with the Regent highlight cast-iron insert with brass embellishment and a black granite hearth.

With cushioned panels and neat proportions, our new Regency design in Imperial white marble was originally produced by John Nash under the patronage of the future King George IV. Paired with the new Cadogan steel and iron basket, and black granite slips and hearth.

This new, solid Regency/William IV mantel in Imperial white marble, designed by Thomas Cubitt, has plain jambs, a curved architrave and moulded corning to the shelf. It is shown with our Modern steel slips and back box, Cubic Modern steel basket and black granite hearth.

A variation on our Grosvenor mantelpiece, this equally imposing new Regency design by Thomas Cubitt in Imperial white marble is distinguished by carved recessed panels on the jambs. It is pictured with our Cadogan polished-steel and iron dog grate, Modern steel slips and black granite hearth.

William IV Corbel	inches	mm
Shelf width	65	1650
Shelf depth	10	254
Base width	57 ³ / ₈	1458
Rebate	1 ¹ / ₂	38
Overall height	49 ¹ / ₄	1255
Opening height	39 ³ / ₄	1010
Opening width	39 ³ / ₈	1000

Nash	inches	mm
Shelf width	64 ¹ / ₂	1638
Shelf depth	8 ¹ / ₂	216
Base width	56	1430
Rebate	1	25
Overall height	45 ¹ / ₂	1156
Opening height	37 ¹ / ₂	952
Opening width	39	990

Grosvenor	inches	mm
Shelf width	70	1778
Shelf depth	12 ¹ / ₄	313
Base width	63 ³ / ₄	1618
Rebate	1	25
Overall height	47	1195
Opening height	35	890
Opening width	32 ³ / ₄	835

Osborne	inches	mm
Shelf width	70	1778
Shelf depth	12 ¹ / ₄	313
Base width	62 ³ / ₄	1597
Rebate	1	25
Overall height	47	1195
Opening height	35	890
Opening width	32 ³ / ₄	835

VICTORIAN CARVED CORBEL



Created from Imperial white marble, this is a superb example of the marble-carver's art and has been specially commissioned by Acquisitions from drawings made over 100 years ago. It is shown with the Albert highlight cast-iron insert and black granite hearth.

Victorian Carved Corbel	inches	mm
Shelf width	58	1473
Shelf depth	10	254
Base width adjustable	54-50	1372-1270
Rebate	1	25
Overall height	45 ³ / ₄	1160
Opening height	36 ¹ / ₂	927
Opening width	36 ¹ / ₂	927

54" / 1372mm shelf also available

FLAT VICTORIAN CLASSIC



Simply elegant: this popular, versatile surround, recreated in Imperial white marble, featured in houses throughout the late-Georgian and Victorian eras. Shown with our Prince highlight insert and a black granite hearth.

Flat Victorian Classic	inches	mm
Shelf width	58	1473
Shelf depth	8	203
Base width adjustable	54-50	1372-1270
Rebate	1	25
Overall height	45 ³ / ₄	1160
Opening height	36 ¹ / ₂	927
Opening width	36 ¹ / ₂	927

54" / 1372mm shelf also available

EDWARDIAN CARVED CORBEL



This Edwardian-style surround in Imperial white marble has a plain frieze and jambs with shaped, carved corbels. We have combined its understated design with our Oxford steel panel and black granite hearth to striking effect.

Edwardian Carved Corbel	inches	mm
Shelf width	58	1473
Shelf depth	10	254
Base width adjustable	54-50	1372-1270
Rebate	1	25
Overall height	45 ³ / ₄	1160
Opening height	36 ¹ / ₂	927
Opening width	36 ¹ / ₂	927

54" / 1372mm shelf also available

DEMI-LUNE BULL'S-EYE



A late-Georgian design of smaller proportions, this Imperial white marble surround has raised panels on its frieze and jambs and bull's-eyes on its frieze blocks. It is paired here with our Cameo polished cast-iron insert and a black granite hearth.

Demi-Lune Bull's-Eye	inches	mm
Shelf width	56 ¹ / ₂	1435
Shelf depth	7	178
Base width	52 ¹ / ₂	1333
Rebate	1	25
Overall height	43 ³ / ₈	1102
Opening height	36 ¹ / ₂	927
Opening width	36 ¹ / ₂	927

54" / 1372mm shelf also available

INIGO



With fine dentil moulding to the shelf and Ionic capitals on baroque-style columns, this bold new surround, conceived by Inigo Jones, is a hybrid of styles. Carved from Imperial white marble, it is pictured with a large London steel hob grate and a black granite hearth.

Inigo	inches	mm
Shelf width	68 ¹ / ₂	1740
Shelf depth	8	203
Base width	62 ³ / ₄	1582
Rebate	1 ¹ / ₂	38
Overall height	52 ³ / ₄	1342
Opening height	41	1040
Opening width	40 ³ / ₄	1038

LINCOLN



A barrel frieze gives a modern twist to this Georgian-influenced fireplace, now available in Imperial white marble. The top shelf section can be left off for smaller chimney breasts. Shown with our new Lorimer steel Serpentine hob grate and black granite hearth.

Lincoln	inches	mm
Shelf width	58	1473
Shelf depth	10 ¹ / ₂	267
Base width	51 ¹ / ₂	1308
Rebate	1 ¹ / ₂	38
Overall height	48 ¹ / ₂	1232
Opening height	36 ¹ / ₂	927
Opening width	36 ¹ / ₂	927

54" / 1372mm shelf also available

LINCOLN GRAND



This new Georgian design in Imperial white marble has the same proportions as the Lincoln, but its baroque-style scrolled console supports give it a more substantial feel. Shown with the Lorimer steel Serpentine hob grate and black granite hearth.

Lincoln Grand	inches	mm
Shelf width	58	1473
Shelf depth	10 ¹ / ₂	267
Base width	51 ¹ / ₂	1308
Rebate	1 ¹ / ₂	38
Overall height	48 ¹ / ₂	1232
Opening height	36 ¹ / ₂	927
Opening width	36 ¹ / ₂	927

Also available in Limestone

Bespoke SURROUNDS

CERTAIN SETTINGS CALL FOR SOMETHING ABOVE AND BEYOND OUR WIDE-RANGING STOCK OF REPRODUCTION FIREPLACES. A BESPOKE CHIMNEYPIECE, MADE TO ORIGINAL SPECIFICATIONS OR DESIGNED AND CREATED FROM SCRATCH AT OUR WORKSHOPS, IS AN IMAGINATIVE OPTION AND ADDS A NOTE OF DISTINCTION TO ANY ROOM. AT ACQUISITIONS WE ALWAYS RISE TO THE CHALLENGE.

You may have practical reasons for using our bespoke service. Perhaps you require one of our standard stock items in an unusual size; maybe you need a match for an existing surround, a particular colour of marble or specialist detailing. Our masons are happy to create an exact copy from photographs or original plans.

Alternatively, we can produce full working drawings with authentic details gleaned from our comprehensive library of reference books. Material samples are provided and the project discussed with you in depth before our in-house craftsmen turn concept into reality.





Have you ever dreamed of owning a sculptural masterpiece as magnificent as our PAIGNTON HOUSE mantel? It was certainly a case of wish-fulfilment for us. We spotted the 19th-century original in a Devon mansion and couldn't rest until we had reproduced it in all its Imperial white marble splendour, complete with imposing caryatids and luxuriant roses. Shown left and on the previous pages teamed with the Dorchester grate, it is now available to order (see dimensions below) or customised for discerning clients everywhere. For our highly skilled masons its creation is a lengthy process involving traditional techniques and tools.

Paington House	inches	mm
Shelf width	77½	1969
Min shelf depth	14½	368
Max shelf depth	17	432
Base width	69½	1765
Rebate	7	178
Overall height	52	1321
Opening height	38	965
Opening width	38	965
Also made in bespoke sizes		

CAST-IRON SURROUNDS

ACQUISITIONS WAS THE FIRST BRITISH COMPANY TO REVIVE THE NECESSARY IRON-FOUNDRY SKILLS AND PRODUCE MANTELS IN THE AUTHENTIC MANNER, WITH PATTERNS DERIVED FROM GEORGIAN RIGHT THROUGH TO EDWARDIAN TIMES. ATTENTION TO DETAIL IS OUR TOP PRIORITY: THESE CAST-IRON DESIGNS – MADE AT THE ORIGINAL SCOTTISH FOUNDRY AND AVAILABLE IN A FULLY POLISHED FINISH – HAVE A CLARITY OF DEFINITION WHICH HAS BECOME THE INDUSTRY’S BENCHMARK FOR QUALITY



The magnificent **PEACE AND PLENTY** exemplifies Acquisitions’ approach to quality iron casting. This ornate period design incorporates two classic allegorical figures – Peace holding an olive branch and Plenty holding the Horn of Plenty and a jug of wine – and is a nostalgic reminder of past excellence. It is shown in a polished finish, along with the Cameo polished insert with coal-effect fire (solid-fuel option available) and a granite hearth.

Peace and Plenty	inches	mm
Shelf width	63 ¹ / ₂	1613
Shelf depth	9	229
Base width	56	1422
Rebate	3 ¹ / ₄	19
Overall height	55 ¹ / ₂	1410
Opening height	36 ¹ / ₂	927
Opening width	34 ¹ / ₂	876





WE PROVIDE ANSWERS TO QUESTIONS WHICH OTHER COMPANIES HAVEN'T EVEN ASKED THEMSELVES YET, AND FIND SOLUTIONS WHERE OUR COMPETITORS HAVE GIVEN UP

◀ The SERPENTINE cast-iron fire surround is pictured in a polished finish, with the Mildmay dog grate and set of four Adam decorative black cast-iron panels.

Serpentine	inches	mm
Shelf width	64 $\frac{1}{2}$	1638
Shelf depth	12 $\frac{1}{2}$	318
Base width	59	1499
Rebate	4 $\frac{3}{4}$	121
Overall height	49	1245
Opening height	37 $\frac{1}{2}$	953
Opening width	37	940

▼ Our elegant REGENCY cast-iron surround is shown in a fully polished finish with the Georgian hob grate and Georgian steel fender.

Regency	inches	mm
Shelf width	62 $\frac{1}{2}$	1590
Shelf depth	9 $\frac{1}{2}$	240
Base width	52	1320
Rebate	3	76
Overall height	52 $\frac{1}{2}$	1330
Opening height	37 $\frac{1}{4}$	945
Opening width	36 $\frac{1}{2}$	925





FIREPLACE INTERIORS

FROM ELEGANT INSERTS AND GRATES TO DECORATIVE PANELS, BASKETS AND FIRE DOGS, AT ACQUISITIONS WE HAVE EVERYTHING YOU NEED TO ENSURE YOUR FIREPLACE IS JUST AS BEAUTIFUL ON THE INSIDE. THE VARIOUS FINISHES AND STYLES PERFECTLY COMPLEMENT OUR SURROUNDS, AND SPECIAL SIZES CAN BE MADE ON REQUEST USING OUR TRADITIONAL MANUFACTURING SKILLS

Some of our painstakingly crafted period designs derive from original historical patterns - we are renowned for our authentically produced cast-iron and steel continuations - and the majority are unique and versatile. Suitable for traditional solid fuel, they can also be used with a gas-effect fire, offering a convenient, mess- and maintenance-free option for busy modern lifestyles. Alternatively, where

no chimney is available we can provide an electric or bioethanol flueless fire, so you can enjoy the beauty of your favourite period or contemporary fireplace wherever you live. If high efficiency is a priority, fires such as our new balanced-flue X-FIRE CUBE, shown overleaf, are ideal solutions. Our attractive and eco-friendly collection of traditional multi-fuel stoves offers even more options as you design the look and overall experience of your dream fireplace.



TRADITIONAL WITH A TWIST... COMBINE A CLASSIC SURROUND WITH A CONTEMPORARY, ADAPTABLE, HIGH-EFFICIENCY GAS FIRE

Our new, highly energy-efficient, balanced-flue X-FIRE CUBE is so versatile it can be easily installed in virtually any room or masonry chimney. Where there is no chimney, this state-of-the-art model can be fitted via any suitable internal or external wall and roof space. Neatly constructed and compatible with all our surrounds, it can also be made in bespoke sizes. Behind its sleek glass front is a remote-controlled log-effect fire, complete with timer and thermostat, that runs on Natural Gas or LPG and boasts impressively low running costs. It is pictured here with our Lincoln limestone surround with matching limestone slips and hearth.

Technical Data

- Efficiency: 86%
- Fuel bed: Logs & Embers
- Gas input: 11kW
- Heat output: 8.5 kW
- Room air vent: None
- Gas: Natural or LPG
- Remote control timer and thermostat
- RX3 RefleXion - rear glass option
- Convection box option to mount TV above fire

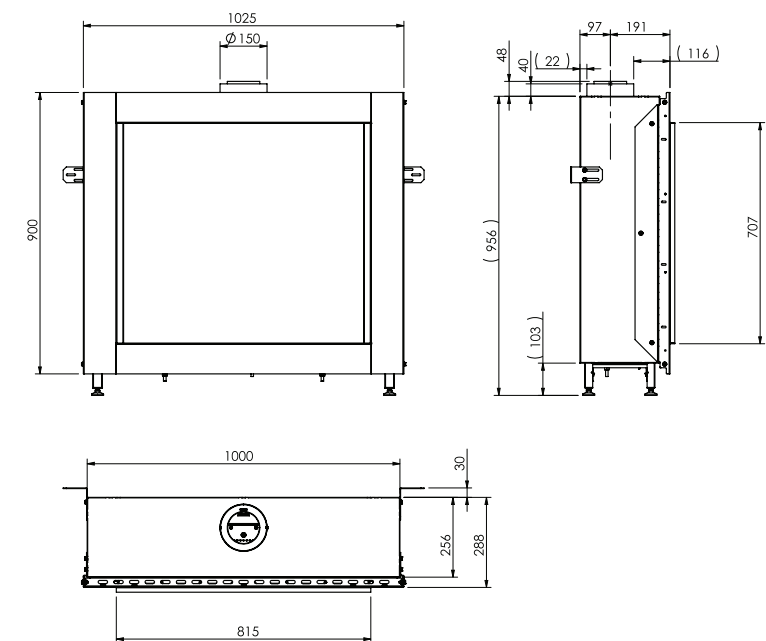

OUR UNIQUE INSERTS ARE MADE TO THE SAME PATTERNS AND EXACTING STANDARDS AS THE ORIGINALS PRODUCED IN THE 18TH AND 19TH CENTURIES. COMPATIBLE WITH OUR RANGE OF MANTELS, THEY ARE SUITABLE FOR SOLID-FUEL, ELECTRIC, FLUELESS BIOETHANOL AND GAS FIRES, INCLUDING REMOTE-CONTROLLED MODELS



SOMERSET

W: 40in (1016mm) H: 40in (1016mm) D: 12¹/₂in (312mm)
Min site opening: Standard W: 27in (686mm) H: 34in (863mm),
Smaller 22 W: 22¹/₂in (565mm) H: 32in (813mm)
Polished mild steel. Made to size



LONDON

W: 40in (1016mm) H: 40in (1016mm) D: 12¹/₂in (312mm)
Min site opening: W: 27in (686mm) H: 34in (863mm)
Polished mild steel. Made to size



STIRLING INSERT

W: 40in (1016mm) H: 40in (1016mm) D: 10³/₄in (260mm)
Min site opening: W: 29in (734mm) H: 34in (863mm)
Polished mild steel. Made to size



LORIMER SERPENTINE

W: 40in (1016mm) H: 40in (1016mm) D: 8in (203mm)
Min site opening: W: 31¹/₂in (800mm) H: 34¹/₂in (870mm)
Polished mild steel. Made to size



DEVONSHIRE

W: 40in (1016mm) H: 40in (1016mm) D: 12¹/₂in (312mm)
Min site opening: W: 27in (686mm) H: 34in (863mm)
Polished mild steel. Made to size



LIBRARY

W: 40in (1016mm) H: 40in (1016mm) D: 12¹/₂in (312mm)
Min site opening: W: 27in (686mm) H: 34in (863mm)
Polished mild steel. Made to size



GEORGIAN HOB

W: 40in (1016mm) H: 40in (1016mm) D: 11¹/₂in (292mm)
Min site opening: W: 30³/₄in (781mm) H: 35¹/₂in (902mm)
Polished cast-iron. One size only.



OXFORD PANEL

W: 40in (1016mm) H: 40in (1016mm)
Min site opening: W: 16in (406mm) H: 22in (559mm)
Polished mild steel. Made to size

ALONG WITH OUR SURROUNDS, OUR TRADITIONAL CAST-IRON CONTINUATIONS GRACE SOME OF THE MOST PRESTIGIOUS ADDRESSES IN THE COUNTRY. THESE INSERTS ARE SUITABLE FOR GAS, BIOETHANOL, SOLID FUEL AND ELECTRIC FIRES



REGENT (HIGHLIGHT/BRASS)

W: 40in (1016mm) H: 40in (1016mm)
D: 12in (305mm) Min site opening:
W: 34in (864mm) H: 33in (838mm)
Cast iron. Available in highlight with brass (shown)



REGENT (HIGHLIGHT)

W: 40in (1016mm) H: 40in (1016mm)
D: 12¹/₂in (320mm) Min site opening:
W: 34in (864mm) H: 33in (838mm)
Cast iron. Available in highlight (shown)



ROYAL

W: 40in (1016mm) H: 40in (1016mm)
D: 9in (229mm) Min site opening:
W: 31¹/₂in (800mm) H: 33¹/₂in (851mm)
Cast iron. Available in black or highlight (shown)



ALEXANDRA

W: 40in (1016mm) H: 40in (1016mm)
D: 9¹/₂in (241mm) Min site opening:
W: 31in (787mm) H: 35in (889mm)
Cast iron. Available in black or highlight polished (shown)



MODERN SLIPS & BACK BOX

W: 40in (1016mm) H: 40in (1016mm)
D: 12¹/₂in (312mm) Min site opening:
W: 29in (738mm) H: 31¹/₂in (817mm)x
Polished mild steel. Made to size. Stove options available.



STIRLING SLIPS & BACK BOX

W: 40in (1016mm) H: 40in (1016mm)
D: 12¹/₂in (312mm) Min site opening:
W: 29in (738mm) H: 31¹/₂in (817mm)
Polished mild steel. Made to size. Stove options available.



CAMEO (POLISHED)

W: 40in (1016mm) H: 40in (1016mm)
D: 10in (254mm) Min site opening:
W: 33in (838mm) H: 32in (813mm)
Cast iron. Available in black, highlight or full polished (shown)



CAMEO (HIGHLIGHT)

W: 40in (1016mm) H: 40in (1016mm)
D: 10in (254mm) Min site opening:
W: 33in (838mm) H: 32in (813mm)
Cast iron. Available in black, highlight (shown) or full polished



ALBERT

W: 40in (1016mm) H: 40in (1016mm)
D: 8in (203mm) Min site opening:
W: 25¹/₂in (648mm) H: 30in (762mm)
Cast iron. Available in black, highlight (shown) or full polished



PRINCE

W: 38in (965mm) H: 38in (965mm)
D: 8in (203mm) Min site opening:
W: 25¹/₂in (648mm) H: 30in (762mm)
Cast iron. Available in highlight (shown)



ADAM PANELS

The Adam set of decorative cast-iron panels is available in matt black and highlight finish. Panels are 36in (915mm) high by either 16in (405mm) or 30in (762mm) wide.

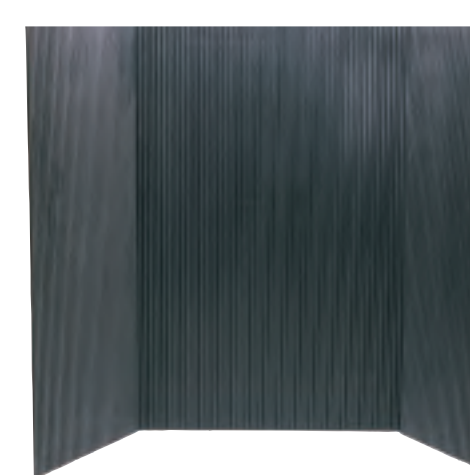

REEDED PANELS

A set of three cast-iron panels finished in matt black. Centre panel 36in (915mm) high by 30in (762mm) wide; side panels 36in (915mm) high by 16in (405mm) wide.

& BASKETS & DOG GRATES

FROM THEIR BRASS AND IRON CASTINGS TO FITTING, POLISHING AND LACQUERING, OUR PERIOD GRATES ARE AUTHENTICALLY CREATED BY SKILLED CRAFTSMEN. ORIGINALLY INTENDED FOR SOLID FUEL, THEY ALSO COME IN ELECTRIC AND GAS COAL OR LOG OPTIONS – AS DO OUR SCULPTURAL MODERN DESIGNS



DORCHESTER

Front W: 35in (889mm) Back W: 22in (559)
H: 29in (737mm) D: 19¹/₄in (495mm)
Available in iron & brass (shown), black or brushed nickel



BLENHIEM

Front W: 28in (711mm) Back W: 19³/₄in (502mm)
H: 29¹/₂in (749mm) D: 14in (356mm)
Available in iron & brass (shown), black or brushed nickel



GEORGIAN

Front W: 24¹/₄in (616mm) Back W: 15in (381mm)
H: 24³/₄in (629mm) D: 12in (305mm)
Available in iron & brass (shown), black or brushed nickel



CUBIC MODERN

W: 26in (660mm) Back W: 17¹/₂in (445mm)
Grate D: 11¹/₂in (292mm)
Dogs D: 11¹/₂in (292mm) H: 9in (229mm)
Polished mild steel. Made to size. Also available in black or bronze finish

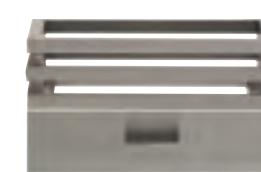

MODERN

W: 17¹/₂in (445mm) H: 9in (229mm)
D: 11¹/₂in (292mm)
Polished mild steel. Made to size. Also available in black or bronze finish

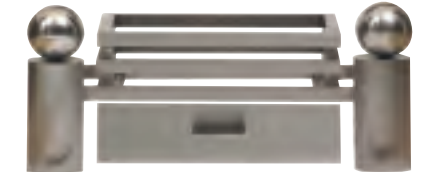

TWO BALL MODERN

W: 26in (660mm) Back W: 17¹/₂in (445mm)
Grate D: 11¹/₂in (292mm) Dogs D: 11¹/₂in (292mm) H: 9in (229mm)
Polished mild steel. Made to size. Also available in black or bronze finish



CONNAUGHT

Front W: 28³/₄in (730mm)
Back W: 18¹/₄in (464mm)
H: 24in (610mm) D: 11³/₄in (298mm)
Available in iron & brass (shown), black or brushed nickel



CHATELAINE

Front W: 24in (610mm)
Back W: 17¹/₂in (445mm)
H: 28in (711mm) D: 13in (330mm)
Available in iron & brass (shown), black or brushed nickel



TRAFALGAR

Front W: 35in (890mm)
Back W: 19in (483mm)
H: 27¹/₂in (699mm) D: 16¹/₂in (420mm)
Available in iron & brass (shown), black or brushed nickel

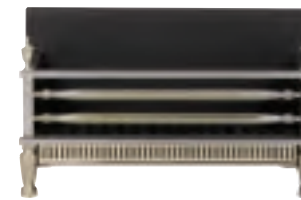

CADAGON

W: 20in (507mm) H: 13in (330mm)
D: 10in (255mm)
Also made to size. Available in Polished (shown) or Black Finish

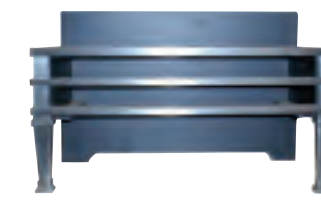

ART DECO

W: 20³/₄in (527mm) H: 13in (330mm)
D: 11¹/₂in (286mm)



BRASS FINIAL GEORGE II FIRE DOGS

D: 10¹/₂in (267mm) H: 27¹/₂in (699mm)
These are limited edition unique brass fire dogs - antiques of tomorrow. Shown with swans nest basket. Available in two sizes.
W: 36in (914mm) D: 16¹/₂in (914mm)
W: 24in (610mm) D: 13in (330mm)



REGENCY

Front W: 30in (762mm) Back W: 19³/₄in (502mm)
H: 29¹/₂in (749mm) D: 16in (406mm)
Available in steel (shown), black or brass finish



MILDMAY

Front W: 23in (584mm) Back W: 20¹/₂in (521mm)
H: 26in (660mm) D: 13in (330mm)
Cast-iron. Available in polished (shown) or black



LARGE ADAM

Front W: 23in (584mm) Back W: 17¹/₂in (438mm)
H: 25in (635mm) D: 13in (330mm)
Cast-iron. Available in polished (shown) or black



DORCHESTER LOW BACK

W: 35in (889mm) Back W: 22in (559mm)
H: 18in (458mm) D: 19in (495mm)
Available in iron & brass (shown), black or brushed nickel



LOUIS

Front W: 19¹/₂in (495mm) Back W: 13in (330mm)
H: 22¹/₂in (572mm) D: 10¹/₂in (267mm)
Also made to size. Available in iron & brass (shown), black or brushed nickel



LARGE FRENCH

Front W: 20¹/₂in (514mm)
Back W: 17¹/₂in (445mm)
H: 24³/₄in (629mm) D: 12in (305mm)
Available in iron & brass (shown), black or brushed nickel

FOUR TYPES OF FUEL

FEW THINGS CONJURE A MOOD OF RELAXED INDULGENCE AS EFFORTLESSLY AS FLAMES FLICKERING IN A GRATE. IF SOLID FUEL IS NOT THE ANSWER FOR YOU, AN ACQUISITIONS FLAME-EFFECT FIRE WILL PROVIDE THE SOOTHING WARMTH AND COLOUR OF A REAL FIRE WITHOUT THE FUSS. OUR UNIQUE DESIGN OF BURNER WITH CERAMIC COALS, LOGS OR PEBBLES MEANS THE VERY LATEST, SAFETY-CONSCIOUS TECHNOLOGY CAN BE INSTALLED IN ALL OF OUR INSERTS AND BASKETS

ELECTRIC

We can provide an electric fire for any of our cast-iron and steel inserts or baskets. Looking for a minimalist alternative? Take your pick of our state-of-the-art electric X-FIRES and relax in the company of unparalleled modern chic. Because no chimney or flue is required, their patented lightweight frames can either be wall-hung or inset into a suitable wall.

GAS

Virtually any working fireplace with a Class 1 chimney is suitable for an Acquisitions gas flame-effect fire. The range caters for most styles of antique and modern fire grates: if, however, your fireplace has unusual specifications that are not matched by any of our standard shapes, we can simply make a template of the base of your grate and produce a burner to order up to 4m wide. We also supply a selection of flame-effect fires suitable for Class 2, pre-cast flues and chimney fans. If high efficiency is a priority, consider our new X-FIRE CUBE gas fire (see page 53 for details).

SOLID FUEL

There's a romance to the traditional fire that makes any room seem welcoming. All Acquisitions inserts and baskets are suitable for solid-fuel use. For impressively efficient and ecologically responsible heating options, see our exclusive new range of authentic, beautifully styled stoves, approved for use in Smoke Control Areas.

BIOETHANOL

No chimney? No problem. All our inserts and baskets can be converted to take our eco-friendly bioethanol burners, which provide real flames and heat without the need for a chimney or flue, as unlike traditional fires no odour or smoke is emitted during the burning process. If your fireplace has unusual proportions that are not catered for by any of our standard shapes, we can design and produce a burner tailored to your needs. Once in place it will bring your Acquisitions fireplace to life with a relaxing flame effect just like the real thing.

NEED TO KNOW

- The information in this brochure is correct at time of going to press. However, we cannot guarantee that it will be 100% accurate at the time of viewing. Please check with your local Acquisitions retailer before purchase.
- All specifications and dimensions are approximate. We reserve the right to alter and improve products without prior notice. Products purchased may differ in specification or appearance from those illustrated/described in this brochure. Due to the printing process and the fact that all homes and chimneys have different characteristics, flame images may vary from those shown. In all cases we strongly advise that products be inspected before both purchase and installation. Neither we nor our retailers can accept responsibility for costs of reinstallation or redecoration relating to products which have not been approved by the purchaser prior to installation.
- Installation and technical requirements should always be checked and discussed with a local Acquisitions retailer prior to purchase. Where technical advice is given by us, it is based on our understanding of the information supplied and is not intended as a substitute for a site survey by a competent person.
- Vents, veins, fossils and fissures are naturally occurring features of stone and marble, and one of the beauties of these materials is that no two pieces are the same. While every effort is made to match markings, you may not receive exactly the same figuring on your chosen model as you see in a showroom or in our brochure. All stone and marble is inherently unsound and requires repair and filling where appropriate. Its beautiful veining or venting is in fact its weakness. Where such repair and filling is necessary, it should not be considered a defect and is quite acceptable provided that the repair work is carefully and professionally executed. These repairs are sometimes stronger than the original material. Some chipping of the edges of the external returns of the legs, back edges of shelves, back panels and slips during transit or fitting is inevitable. These edges should be hidden when rebated behind the fireplace opening or chased into the wall. This is normal practice and acceptable provided the chips are not detrimental to the overall appearance of the fireplace. The materials we use for our stone surrounds are solid natural limestone, sandstone, granite and marble. Quarrying and cutting involves large quantities of water: this is absorbed by the stone, so individual components may vary in colour while drying. Shade variation may also be evident after fitting, as water is used during installation. In time the stone will dry

- to a uniform appearance. Drying-out times depend on the stone thickness, room ambience and installation procedure.
- Natural materials should be maintained with care according to the cleaning instructions provided. Painted, polished and finished surfaces may discolour during use due to heat: it is very important that the cleaning and installation instructions provided are followed. If in doubt, consult your retailer. Metal surfaces require regular protection against moisture ingress. It is normal for fuel-bed ceramics to crack in use due to shrinkage. Carbon deposits are a natural by-product of the combustion process and pebble ceramics may be affected.
- We pursue a policy of continuous development, constantly striving to improve our collection and keeping the environment high on our agenda. We always aim to design the most efficient gas fires possible, so that over time all our products will minimise fuel and energy usage and provide maximum heat output for the fuel used.
- We are committed to preventing pollution and aim to continuously improve our own environmental performance as well as that of our products. We comply with relevant environmental legislation and safety regulations. Our objective is to minimise or, wherever practical, eliminate wastage in production, delivery and packaging.
- Acquisitions XERO and our other flueless fires have been developed to meet demand for real-flame fires with modern levels of efficiency, thereby aiding in the reduction of CO₂ emissions and helping to extend fossil fuel reserves.
- Unlike many gas fireplaces, XERO flueless is easy and inexpensive to install if you don't have a chimney. If you are concerned about rising fuel prices, a flueless fire will probably be the answer. It saves up to 68% of the running costs of a conventional 7kW gas fire and produces lower CO₂ emissions.
- Flueless fires, while extremely efficient, should not be regarded as a primary source of heat. We recommend they be installed in conjunction with an additional form of heating, such as central or underfloor.
- Nearly all conventional fires lose some of their heat through a chimney. Just 20% of the heat generated by a traditional open solid-fuel fire reaches the room, while an open decorative gas fire is typically 30 to 50% efficient. Even when an open gas or solid-fuel fire is not in use it can take existing room heat from sources such as radiators and storage heaters. It should not be assumed that a new

- gas fire will provide more heat than an existing appliance. Electric fires are said to be 100% efficient, but this does not take into account transmission losses between the power station and your home, which can be as high as 70%.
- Our flueless models, on the other hand, really are 100% efficient. Even allowing for the room air vent that is required by law, the best SAP2005 (energy efficiency) ratings for new-build houses are achieved when a flueless fire is specified, when compared to any other gas fire.
- Decorative fires are a secondary source of heat. All our open and flueless gas fires are fitted with an oxygen depletion sensor and are CE marked. Where appropriate, a fireguard should be used, especially when the young, elderly or infirm are present.
- All gas fire installations must comply with the relevant installation instructions and regulations. All dimensions should be physically checked before commencing installation, cutting fireplace materials and/or constructing a false chimney breast. Please note that all gas fires should be installed and then serviced annually by a Gas Safe or registered installer (three-year warranty claims will require proof of annual servicing).
- Our design and quality control criteria ensure that relevant appliances comply with British, European, North American or other international safety and operational standards.
- Your statutory rights are unaffected. Our three-year XERO warranty enhances your protection.

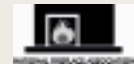

© Acquisitions of London 2012. All rights reserved. None of our designs or any part of this brochure may be reproduced without prior written permission. Our designs are protected as Registered Designs. Acquisitions of London, Acquisitions X-FIRES, X-FIRES and RX3 Reflexion Technology are all trademarks of Acquisitions Fireplaces Limited.

